



RAYCHEM TERMINATIONS

FOR POLYMERIC AND MIND PAPER
INSULATED CABLES FROM 7.2 KV
UP TO 36 KV

Raychem Terminations

for Polymeric and MIND Paper Insulated Cables from
7.2 kV up to 36 kV

This worksheet enables you to arrive at a part number for a Raychem termination EPKT.

Choose one figure from the left-hand column of each table.

Typical part number:

EPKT- 17C3MOH3 B21 G43

Voltage (U_{max})

Cable size

Number of cores

Dielectric

Location

Length (3-core-cables)

Accessories

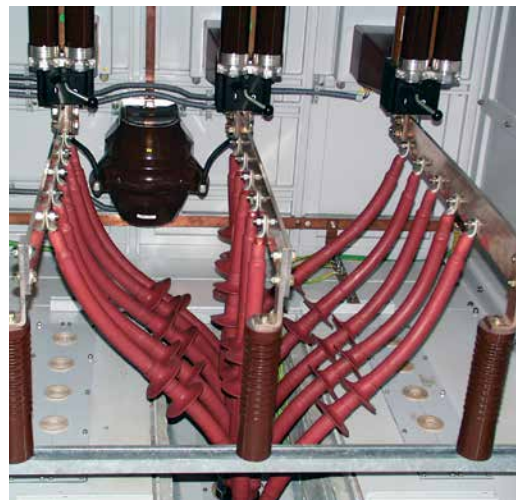

VOLTAGE IN KV

7	for 7.2 kV
17	for 12 kV & 17.5 kV
24	for 24 kV
36	for 36 kV

SIZE IN MM ²	7.2 kV	12 kV & 17.5 kV	24 kV	36 kV
A	16 - 50	16 - 25	-	-
B	70 - 120	35 - 70	25 - 50	-
C	150 - 240	95 - 240	70 - 185	50 - 95
D	300 - 500	300 - 400	240 - 300	120 - 185
E	630 - 1000	500 - 800	400 - 630	240 - 500
F	-	1000	800 - 1000	630 - 1000

NUMBER OF CORES

1	for single (1) core
3	for three (3) cores

DIELECTRIC OF INSULATION TYPE

X	for PLASTIC eg. XLPE, EPDM, EPR, etc.
M	for MIND non-draining paper (not applicable for draining paper cables)

LOCATION OF THE TERMINATION

I	for INDOOR
O	for OUTDOOR

LENGTH (ONLY 3-CORE) OF THE TERMINATED PORTION (TAIL)

H1	for 450 mm long
H2	for 650 mm long (min for 17.5 kV outdoor & 36 kV indoor)
H3	for 800 mm long (min for 24 kV outdoor & 36 kV outdoor)
H4	for 1200 mm long

Raychem Terminations

for Polymeric and MIND Paper Insulated Cables from 7.2 kV up to 36 kV

Armour earthing

Wire armour in paper or plastic cables can be effectively terminated to earth by means of mechanical clamping rings. Heat-shrinkable tubing for corrosion protection and an insulated copper conductor for earth connection are also included.

The kits can be ordered separately or with the termination by adding the mod code to the end of the part number.

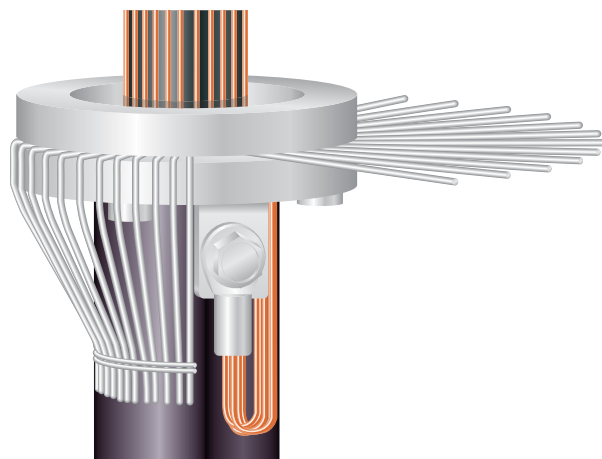

1-CORE CABLES

Diameter Mod Code Range (mm)	Application Range (mm ²)					Part Number
	7.2 kV	12 kV	17.5 kV	24 kV	36 kV	
21 - 32	16 - 70	16 - 70	16 - 50	16 - 50	-	EAKT 1636 G 36
33 - 50	95 - 400	95 - 400	70 - 400	70 - 300	16 - 185	EAKT 1637 G 37
51 - 67	500 - 800	500 - 800	500 - 800	400 - 800	240 - 630	EAKT 1638 G 38

1-CORE CABLES

Diameter Mod Code Range (mm)	Application Range (mm ²)					Part Number
	7.2 kV	12 kV	17.5 kV	24 kV	36 kV	
40 - 67	16 - 120	16 - 120	16 - 95	16 - 35	16 - 25	EAKT 1642 G 42
50 - 86	150 - 240	150 - 240	120 - 185	50 - 120	35 - 95	EAKT 1643 G 43
60 - 94	300 - 400	300 - 400	240 - 300	150 - 185	120 - 185	EAKT 1644 G 44
70 - 110	-	-	-	240 - 300	240 - 300	EAKT 1645 G 45

Cable preparation kit

Two types of cable preparation kits are also available. The one for paper cable contains cleaning solvent, solder and binding wire.

The one for plastic cable contains abrasive paper, string, cleaning tissues and plastic gloves. These can only be ordered along with terminations by adding the mod code to the end of the part number.



Application	Mod Code
Paper cable	E 01
Plastic cable	E 02

Raychem Terminations

for Polymeric and MIND Paper Insulated Cables from
7.2 kV up to 36 kV

Cable glands

The Raychem cable gland is used with a wide range of cable boxes designed for compound filling where the distance from bushing to base-plate is a limiting factor. The gland is made to match stud spacings to BS 2562.

It is also available with an insulating plate for separate earthing and of aluminium for single core applications. These can be ordered separately as complete kits or along with the termination by adding the mod code at the end of the part number.

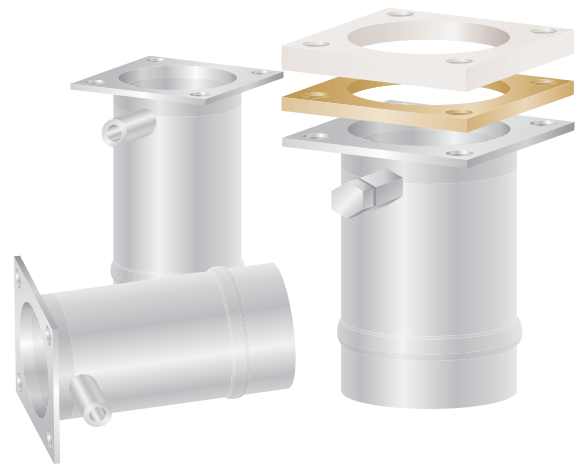

Application	Part Number	Mod Code
Steel/Small/X-Type/cables up to 95 mm ²	EAKT 1605	G 05
Steel/Large/Y-Type/cables up to 300 mm ²	EAKT 1606	G 06
Steel/Large/Y-Type/with insulating plate	EAKT 1607	G 07
Aluminium/Small/X-Type/1-core application	EAKT 1608	G 08

Note:

The stud hole spacing in the small gland is 66 mm x 66 mm and in the large gland is 86 mm x 95 mm.

Solderless earth connection

Copper tape screens on plastic cables can be earthed mechanically by using Raychem's solderless earth connection system. The kit comes complete with a tinned copper earthing braid and a mechanical roll spring for each phase.

These can be ordered separately as kits or with the termination by adding the mod code to the end of the part number.

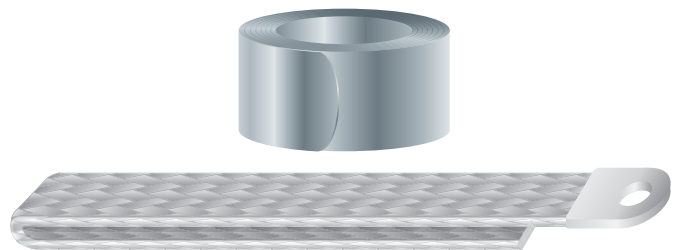

Diameter over Mod Code (mm)	Application Range (mm ²)						Part Number
	7.2 kV	12 kV	17.5 kV	24 kV	36 kV		
12 - 18	16 - 50	16 - 50	16 - 25	-	-	EAKT 1655	G 55
19 - 24	70 - 150	70 - 150	35 - 95	25 - 70	25 - 35	EAKT 1656	G 56
25 - 30	185 - 300	185 - 240	120 - 185	95 - 150	50 - 70	EAKT 1657	G 57
31 - 44	400 - 630	300 - 630	240 - 500	185 - 500	95 - 300	EAKT 1658	G 58
41 - 65	800 - 1000	800 - 1000	630 - 1000	630 - 1000	400 - 1000	EAKT 1659	G 59

Note:

Solderless earth connections are also available for lead sheaths on paper cables. For such requirements please contact your local sales representative.

Raychem Terminations

for Polymeric and MIND Paper Insulated Cables from 7.2 kV up to 36 kV

Boots

Insulating boots are moulded parts which are shrunk over the connection between the cable lug and bushing to insulate them. They are used in switchgear and transformers with compound filled boxes where the clearances are insufficient for operation in air or to protect against flash over due to rodents or extreme humidity.

A full range of insulating boots are available up to 17.5 kV. These can be ordered separately by quoting the part number or with the termination by adding a mod code to the end.

Example:

EPKT-17C3MOH3-B07 This kit comes complete with straight boots.

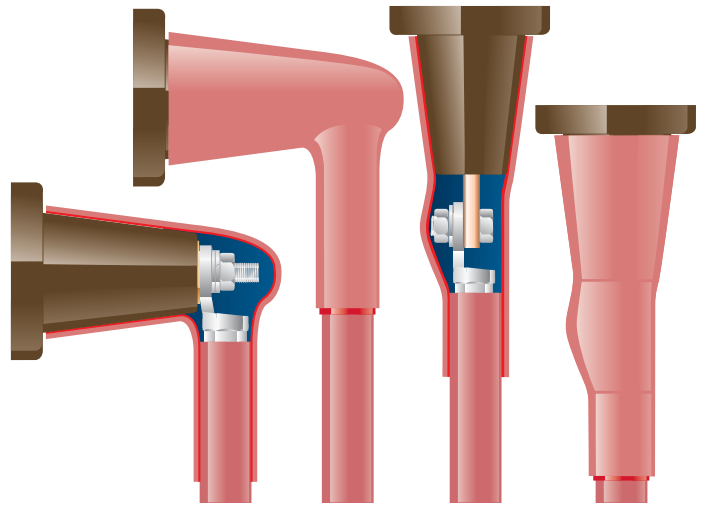

Application range	Straight boots		Right angle boots - long		Right angle boots - short	
	Mod Code	Part Number	Mod Code	Part Number	Mod Code	Part Number
10 - 35 mm ²	B05	RSRB 4022	B08	RSRB 4042	B15	RSRB 4062
50 - 95 mm ²	B06	RSRB 4024	B09	RSRB 4044	B16	RSRB 4064
120 - 300 mm ²	B07	RSRB 4026	B10	RSRB 4046	B17	RSRB 4066

Note:

1. Long boots are 110 mm long over the bushing. The short boots are 90 mm long.
2. Insulating boot kits are also available for up to 36 kV applications.
For such requirements please refer to your local sales representative.

Support insulators and bracket

We also manufacture a range of hybrid insulators. The sheds of red, non tracking, flexible polymeric material are mounted on a porcelain core.

Sets of three, along with a galvanised steel T-bracket, can be ordered for applications up to 36 kV either as separate kits by quoting the part number or with the termination by adding the mod code to the end.

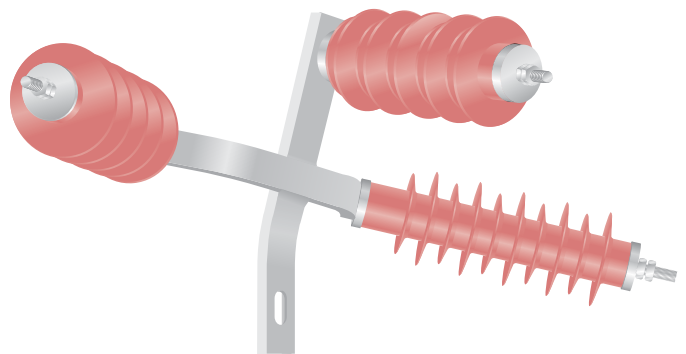

Reference standard IEC 60815, IEC 60071

Part Number	Mod Code	Description			
		(pollution level IV)	(pollution level III)	(pollution level II)	(pollution level I)
EAKT 1521	B 21	Insulator Kits 12 kV	-	Insulator Kits 17.5 kV	Insulator Kits 24 kV
EAKT 1523	B 23	Insulator Kits 17.5 kV	Insulator Kits 24 kV	-	Insulator Kits 36 kV
EAKT 1524	B 24	Insulator Kits 24 kV Insulator Kits 36 kV	-	-	-

Note:

The voltage is the highest phase-to-phase voltage U_{max}

Raychem insulated adapter termination system RICS for SF₆-insulated switchgear up to 24 kV

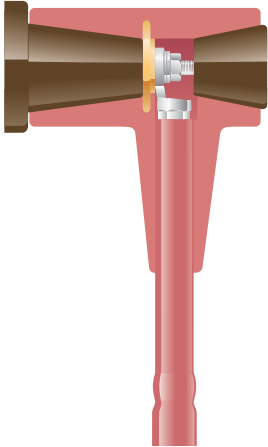

T-adapter for perpendicular connection of the termination to SF₆-insulated switchgear

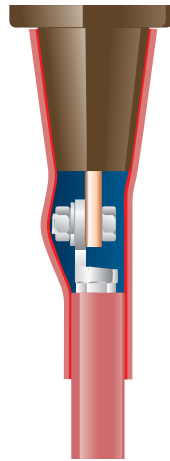

T-adapter for perpendicular connection of termination and surge arrester to SF₆-insulated switchgear

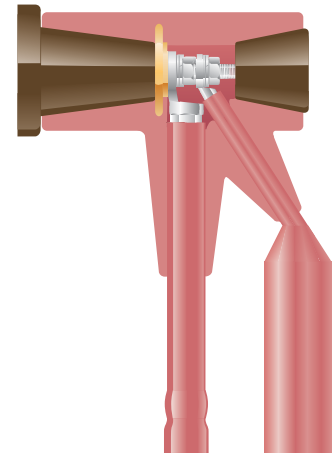

Straight adapter for vertical connection of the termination to SF₆-insulated switchgear

T-adapter

The insulated adapter termination system provides perfect sealing, electrical insulation and an electrical connection between Raychem terminations and SF₆-insulated switchgear up to 24 kV. Its lead-in insulator (630 A) conforms to DIN 47636 and ANSI IEEE 386.

The cable box of the switchgear must be provided with suitable protection against electric shock. The insulating adapter is compatible with all Raychem terminations. Details of the terminations can be found in the cable accessories catalogue.

The insulating body, fixing bolts, terminal stud and backplug are supplied in a 3-phase set complete with installation instruction. Cable lugs and terminations are not included.

For double T-connections, the second adapter is of special design and includes connection plug, insulating body, fixing bolts, terminal stud and backplug. It can be combined with first Raychem adapters of type RICS-57x3-CU with M16 lugs, but not with Raychem adapter for surge arresters type RICS-51x9.

T-adapter with surge arrester

Thick walled insulator made of high quality elastomer with sealing face over the termination, bushing cone and plug.

The electrical connection is made with a terminal stud and the cable lug of the termination. Two cable connection is possible. A special plug which allows cable testing without disconnecting the adapter is also offered.

The design of the adapter for connecting the surge arrester is basically identical. The elastomer insulator has an additional lead-in duct for the surge arrester. Details of the surge arresters can be found in the brochure EPP 0533.

Scope of supply (for three phases)
Insulator, plug, terminal stud, small accessories and installation instructions.

Straight adapter

A thick walled, heat-shrinkable insulating sleeve provides a hermetic seal over the cone of the bushing and the termination. The adapter area is smoothed with a meltable filler strip.

Scope of supply (for three phases)
Heat-shrinkable insulating sleeving, filler strip, small accessories and installation instructions. Terminal stud and lug must be enclosed.

Raychem Terminations

for Polymeric and MIND Paper Insulated Cables from
7.2 kV up to 36 kV

Raychem insulated adapter termination system RICS for SF₆-insulated switchgear up to 24 kV

RAYCHEM RICS T-ADAPTER				
Voltage class (U _o / U (Um)kV)	Cable type	Application range (mm ²)	Type of indoor termination	Part Number
6.35 / 11 (12)kV	Polymeric 1C & 3C	25 to 50 70 to 150 185 to 240 300	IXSU-F, POLT, EPKT, TFTI	RICS 5113 RICS 5123 RICS 5133 RICS 5143
8.7 / 15 (17,5)kV	Polymeric 1C & 3C	25 to 35 50 to 95 120 to 185 240 to 300	IXSU-F, POLT, EPKT, TFTI	RICS 5113 RICS 5123 RICS 5133 RICS 5143
2.7 / 22 (24)kV	Polymeric 1C & 3C	10 to 70 95 to 185 240 to 300	IXSU-F, POLT, EPKT, TFTI	RICS 5123 RICS 5133 RICS 5143
6.35 / 11 (12)kV	Paper (MI and MIND) Belted	35 50 to 95 120 to 185 240	EPKT-45xx	RICS 5113 RICS 5123 RICS 5133 RICS 5143
6.35 / 11 (12)kV	Paper (MI and MIND) Screened or belted	35 to 70 95 to 150 185 to 240 300	EPKT	RICS 5113 RICS 5123 RICS 5133 RICS 5143

RAYCHEM RICS T-ADAPTER WITH SURGE ARRESTER				
Voltage class (U _o / U (Um)kV)	Cable type	Application range (mm ²)	Type of indoor termination	Part Number
6.35 / 11 (12)kV	Polymeric 1C & 3C	NA NA 185 to 240 300	IXSU-F, POLT, EPKT, TFTI	RICS 5139 RICS 5149
8.7 / 15 (17,5)kV	Polymeric 1C & 3C	NA NA 120 to 185 240 to 300	IXSU-F, POLT, EPKT, TFTI	RICS 5139 RICS 5149
12.7 / 22 (24)kV	Polymeric 1C & 3C	NA 95 to 185 240 to 300	IXSU-F, POLT, EPKT, TFTI	RICS 5139 RICS 5149
6.35 / 11 (12)kV	Paper (MI and MIND) Belted	NA NA 120 to 185 240	EPKT-45xx	RICS 5139 RICS 5149
6.35 / 11 (12)kV	Paper (MI and MIND) Screened or belted	NA NA 185 to 240 300	EPKT	RICS 5139 RICS 5149

Tests:

The adapters meet Cenelec HD629.1S1, IEC 540, VDE 0278 and ANSI IEEE 386 standards, as well as the Raychem specification PPS 3013, in addition they were type tested together with most switchgear. The test requirements and results are summarised in Raychem test reports, which are available on request.

Raychem Terminations

for Polymeric and MIND Paper Insulated Cables from 7.2 kV up to 36 kV

Raychem elastomeric insulating bushing boot RCAB for bushings up to 17.5 kV and 24 kV

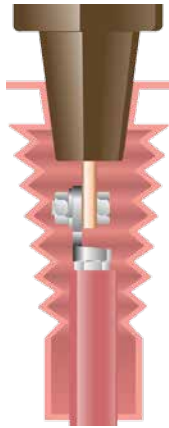

Raychem right angle or inline application RCAB up to 17.5 kV

Raychem elastomeric insulating boots are moulded parts which fit over the connection between the cable lug and the inline or right-angled equipment bushing to improve phase-to-phase and phase-to-ground insulation. They are used in switchgear and transformer cable boxes where the air clearances are insufficient for normal operation, or to protect against flashover due to rodents or high humidity. The non-tracking elastomeric housing has excellent erosion resistance, dielectric properties and environmental resistance, giving superb performance in areas of high humidity and electrical stress.

Raychem boots RCAB work in combination with all Raychem termination product lines including both elastomeric and traditional heatshrink technology. Raychem boots RCAB are quick and easy to install and do not require any taping of the bushing or the termination. The boot can easily be removed and reinstalled without the need for additional material or tooling, allowing access to the bushing connection for test purposes. The universal screw EXRM-1366 is available on request. Each kit contains elastomeric insulating boots, collars (if required) for three phases and installation instructions.

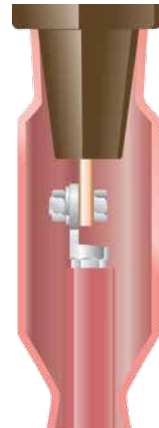

Raychem inline application RCAB up to 24 kV

The insulating body is supplied in a 3-phase set complete with installation instruction. Fixing bolts, terminal stud and cable lugs are not included. Terminal studs with a M16 thread can be ordered separately as EXRM 1366. The adapter is to be used in combination Raychem terminations.

RAYCHEM ADAPTER RCAB

Voltage class (U_0 / U (Um))kV	Cable type	Application range (mm ²)	Type of indoor termination	Part Number
6.35 / 11 (12)kV	Polymeric 1C & 3C	35 to 300	IXSU-F, POLT, EPKT, TFTI	RCAB 4120
12.7 / 22 (24)kV	Polymeric 1C & 3C	50 to 300	IXSU-F, POLT, EPKT, TFTI	RACB 5120

Tests

The adapters meet Cenelec HD629.1S1, IEC 540, VDE 0278 and ANSI IEEE 386 standards, as well as the Raychem

specification PPS 3013, in addition they were type tested together with most switchgear. The test requirements and

results are summarised in Raychem test reports, which are available on request.

te.com/energy

©2016 TE Connectivity Ltd. family of companies. All Rights Reserved. EPP-0282-2/16

Raychem, TE Connectivity and TE Connectivity (logo) are trademarks. Other logos, product and/or company names might be trademarks of their respective owners. While TE has made every reasonable effort to ensure the accuracy of the information in this brochure, TE does not guarantee that it is error-free, nor does TE make any other representation, warranty or guarantee that the information is accurate, correct, reliable or current. TE reserves the right to make any adjustments to the information contained herein at any time without notice. TE expressly disclaims all implied warranties regarding the information contained herein, including, but not limited to, any implied warranties of merchantability or fitness for a particular purpose. The dimensions in this catalog are for reference purposes only and are subject to change without notice. Specifications are subject to change without notice. Consult TE for the latest dimensions and design specifications.

FOR MORE INFORMATION: TE Technical Support Centers

USA:	+ 1 800 327 6996
France:	+ 33 380 583 200
UK:	+ 44 0870 870 7500
Germany:	+ 49 896 089 903
Spain:	+ 34 916 630 400
Italy:	+ 39 333 250 0915
Benelux:	+ 32 16 351 731
Canada:	+ 1 (905) 475-6222
Mexico:	+ 52 (0) 55-1106-0800
Latin/S. America:	+ 54 (0) 11-4733-2200
China:	+ 86 (0) 400-820-6015