



**CABLE
SERVICES**

Trace

Heating

Guide

Visit our web site at: www.cableservices.co.uk

TRACE HEATING GUIDE

Distributor of tyco
Trace Heating Products
for 25 Years

-  (Northwest) Ltd
Tel 01978 356948
-  (UK) Ltd
Tel 01978 340450
-  (Central) Ltd
Tel 01782 274714
-  (Liverpool) Ltd
Tel 0151 9339022



RS 21752
RS 21753
RS 22195
RS 14517









Our History of Trace Heating

Cable Services started distributing the Raychem range of self regulating Trace Heating cables in the late seventies and have over the years acquired a wide expertise in the installation of the whole range of Tyco Trace Heating products.

Our vast experience coupled with stocks unequalled anywhere in the UK makes Cable Services the only choice for Trace Heating materials.

Ring our experienced sales staff on the numbers listed across or use the fax back form opposite to send us details of your requirements. An immediate response is our commitment.

Contents

-  **4 Trace Heating Products** Page 4 - 8
Tyco trace heating products including Raychem Isopad, Wintergard and Frostop. Systems for commercial and industrial freeze protection and process control. Also ice protection, floor warming and leak detection products.
-  **9 Industrial Trace Heating Guidelines** Page 9 - 17
Page 9 General Information
Page 9 Heating Cable Selection
Page 9 - 13 Heating Cable Installation
Page 14 - 15 Pipe Heat Loss Chart
Page 16 - 17 Heat Tracing Plastic Pipes with Chemelex Auto-Trace Self-Regulating Heaters
-  **18 Domestic / Commercial Trace Heating Guidelines** Page 18 - 19
Page 18 Raychem Wintergard
Page 19 Raychem HWAT Hot Water Temperature Maintenance
-  **20 Troubleshooting Guide** Page 20 - 21
-  **22 Thermostats** Page 22 - 23
-  **23 Rule Of Thumb** Page 23

Data Input Sheet - Fax Back

For our FREE design proposal please complete the data input sheet below and fax it to a Cable Services sales office.

Size of Pipe (ø):

Length of Pipe:

Material of Pipe:

Thickness & Type of Insulation:

Ambient Temperature:

(surrounding air, min & max)

Temperature:

(to be maintained, ie 5°C for frost protection)

Maximum Temperature:

(on the pipe ie through steam cleaning etc)

Indoors Outdoors

Hazardous Non-Hazardous

Number of Valves:

Number of Pipe Supports:

Supply Voltage

Additional Information:
(general description of project etc)

.....

.....

.....

Name:

Company:

Tel No:

Fax No:



SALES OFFICE FAX NUMBERS

 **Northwest Ltd**
Fax: 01978 310438

 **UK Ltd**
Fax: 01978 311315

 **Central Ltd**
Fax: 01782 280547

 **Liverpool Ltd**
Fax: 0151 9339765

tyco Thermal Controls

Electric Trace Heating

For frost protection and temperature maintenance.

Cable Services have distributed Raychem Trace Heating products for over 20 years.

The extended range of products now available from Tyco Thermal Controls includes the Raychem, Pyrotenax and Isopad products many of which are stock items at Cable Services.

Products available include:

Raychem WinterGard™ and Frostop

For self regulating heating cable for domestic and commercial freeze protection.

Wintergard™ and Frostop heating cables are safe and reliable. Self regulating technology prevents overheating and minimises energy consumption and parallel circuit configuration means cables can be cut to length on site.

Contact Cable Services with application requirements for a design recommendation and quotation. (See page 3 for our simple data input sheet).



Raychem HWAT™ Plus

For self regulating heating for hot water temperature maintenance.

Hot water temperature maintenance using HWAT™ Plus self regulating trace heating cable combines instant hot water in large and small buildings with improved energy efficiency over traditional hot water systems.

Contact Cable Service for a free design proposal and quotation.



tyco Thermal Controls

T2 Floor Heating

Flexible, reliable and easy to install floor heating.

The T2 floor heating product range is designed to provide room heating from floor up, heating the room much more evenly than traditional systems, and ensuring that the floor is the warmest place in the room.

Contact Cable Services for a free design proposal and quotation.

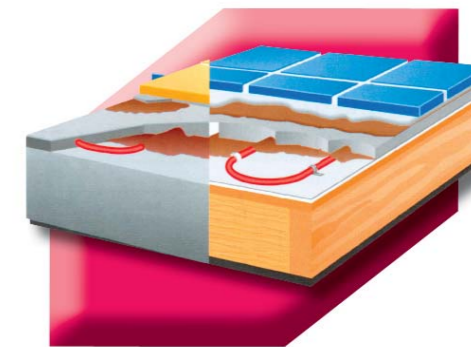

Raychem Self Regulating BTV ^{Ex}

Electric trace heating for frost protection in industrial applications without steam cleaning.

The BTV family of self regulating parallel circuit heating cables is used for frost protection of pipes and vessels. It can be used for process temperature maintenance up to 65°C and has an unlimited T6 rating for hazardous areas.

Contact Cable Services with application details for a design recommendation and quotation. (See page 3 for our simple data input sheet).

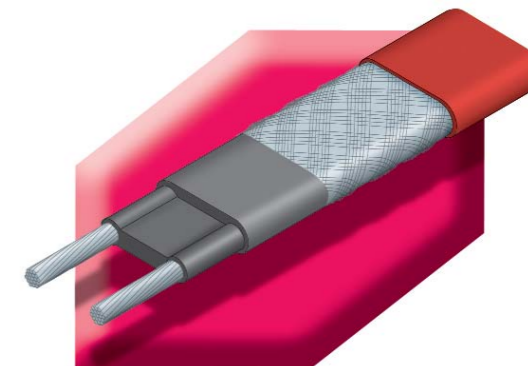

Raychem Self Regulating QTVR ^{Ex}

Electric trace heating for industrial process temperature maintenance applications up to 110°C, not subject to steam cleaning.

The QTVR family of self regulating parallel circuit heating cables is used for process temperature maintenance of pipes and vessels in industrial environments. It can also be used for frost protection on large diameter pipes and has a T4 rating for hazardous areas.

Contact Cable Services with application details for a design recommendation and quotation. (See page 3 for our simple data input sheet).

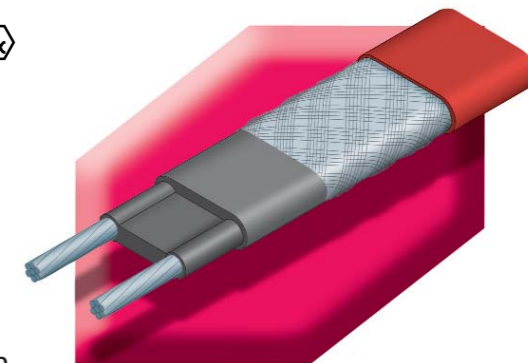

tyco Thermal Controls**Raychem Self Regulating XTV** 

Electric trace heating for process temperature maintenance applications up to 120°C which may be subject to steam cleaning.

The XTV family of self regulating parallel circuit heating cables is used for process temperature maintenance of pipes and vessels in industrial environments where there may be a requirement to steam clean. It can also be used for frost protection of large diameter pipes and other applications requiring high temperature exposure capability. XTV heaters are rated T3 and T2 (20XTV2 - CT) for hazardous area applications.

Contact Cable Services with application details for a FREE design recommendation and quotation. (See page 3 for our simple data input sheet).

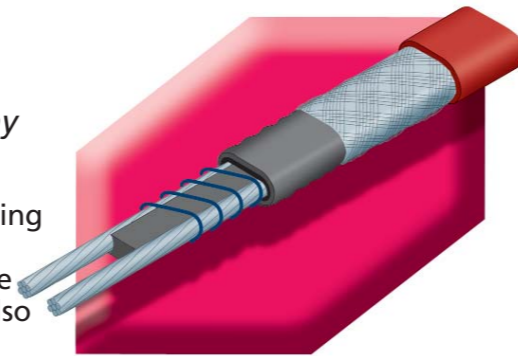
**Raychem Self Regulating KTV** 

Electric trace heating for process temperature maintenance applications up to 150°C which may be subject to steam cleaning.

The KTV family of self regulating parallel circuit heating cables is used for industrial process temperature maintenance of pipes and vessels, where there may be a requirement for a high temperature exposure capability. KTV heaters are rated T3 and T2 for hazardous area applications.

Contact Cable Services with application details for a FREE design recommendation and quotation. (See page 3 for our simple data input sheet).

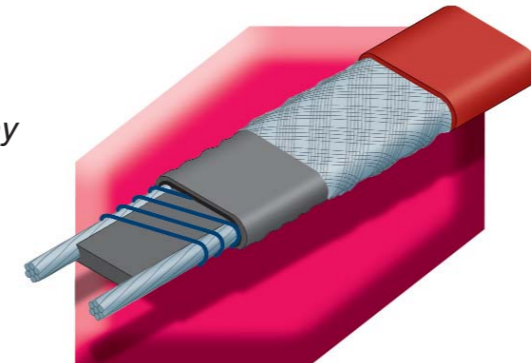
**Raychem High Temperature Power Limiting VPL** 

Electric trace heating designed for high temperature industrial applications up to 250°C temperature exposure.

VPL is a family of power limiting cables which can be used for frost protection and process temperature maintenance requiring high power output and/or high temperature exposure. VPL can provide process temperature up to 230°C and can withstand routine exposure to 250°C with power off. Power limiting cables are 'parallel circuit' heaters formed by a coiled resistor alloy heating element wrapped around two parallel conductors. This parallel construction allows it to be cut to length on site.

Contact Cable Services with application details for a FREE design recommendation and quotation. (See page 3 for our simple data input sheet).

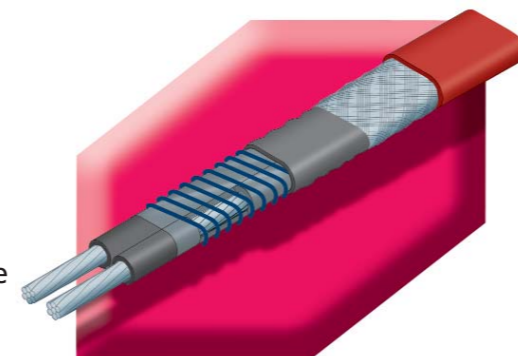
**tyco Thermal Controls****isopad Constant Wattage IHT**

IHT parallel circuit medium power constant output heater for non hazardous areas.

IHT is designed for high temperature process maintenance applications particularly in chemically aggressive environments such as animal fats. The parallel circuit zone construction enables IHT to be cut to length and terminated on site.

Contact Cable Services with application details for a FREE design recommendation and quotation. (See page 3 for our simple data input sheet).

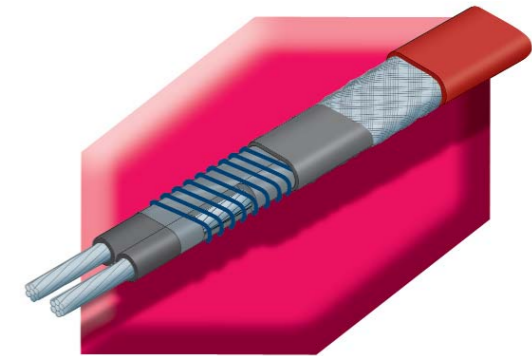
**isopad Constant Wattage FHT** 

FHT constant wattage parallel circuit heating cables for high power industrial applications including hazardous areas.

FHT is designed for high temperature applications and can provide process temperature maintenance up to 150°C and can withstand exposure up to 260°C power off. The parallel construction allows it to be cut to length on site and its round shape provides excellent flexibility during installation.

Contact Cable Services with application details for a FREE design recommendation and quotation. (See page 3 for our simple data input sheet).

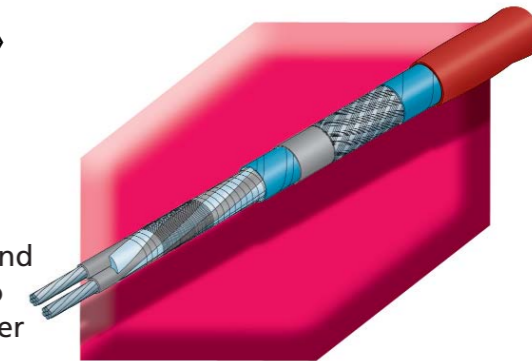
**isopad Constant Wattage FG220**

Versatile flexible parallel circuit heater for medium power applications in non hazardous areas.

FG220 is a family of silicone rubber jacketed highly flexible constant wattage heaters suitable for a variety of industrial applications in non hazardous, non chemical aggressive industrial environments. A stainless steel overbraid is available as an option.

Contact Cable Services with application details for a FREE design recommendation and quotation. (See page 3 for our simple data input sheet).

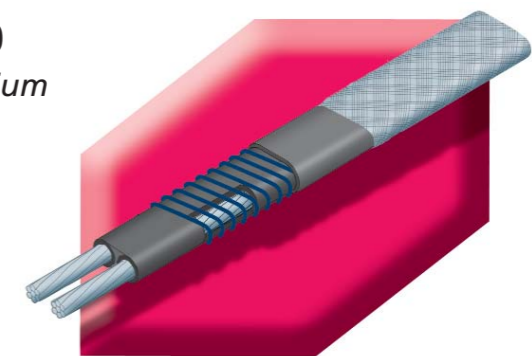

tyco Thermal Controls

VIAGARD System

Ice and snow protection for ramps, steps and footpaths.

Viagard self regulating cables buried in the concrete or tarmac surface keeps ramps etc clear of snow and ice allowing continuous safe access. The Viagard system offers toughness, versatility and reliability.

Contact Cable Services with details of your application for a FREE design proposal and quotation.



Raychem ICESTOP System

For snow and ice prevention on roofs and in gutters.

The Icestop system features a self regulating heating cable specially developed to prevent ice formation on almost any type of roof. The heat output adjusts at each point along the cable, with highest output in snow and icy water and decreasing in warmer, dryer areas. The self regulating construction ensures the cable cannot overheat and thus provides a safe and economical means of ice protection.

Contact Cable Services with details of your application for a FREE design proposal and quotation.



Apart from the heating cables described, the range of products available now includes the ISOPAD series heaters for very high temperature applications and the ISOPAD heated hoses and drum heaters. Please contact sales for details

Raychem TraceTek

Leak detection cables.

Raychem also manufactures TRACETEK leak detection cable. This cable is installed in sensitive areas where the consequence of an undetected flood could be disastrous.

Please contact the Cable Services sales office for further details.



GENERAL INFORMATION

This installation information is for Raychem Self-Regulating Heater Systems on thermally insulated pipes only. For information regarding other applications contact Cable Services.

Warning

As with any electrical equipment or wiring installation operating at line voltages, heating cable and component damage or incorrect installation that allows the penetration of moisture or contamination can lead to electrical tracking, arcing and potential fire hazard.

Do not connect a heater's conductors together or this will result in a short circuit.

Any unconnected heating cable end must be sealed with a Raychem approved end seal.

Heating Cable Selection

Check the design specification to make sure the proper heater is installed on each pipe. Refer to Cable Services for help in selecting the proper heating cable for each thermal, chemical, electrical and mechanical environment.

Heating Cable Installation

1.1 Heating Cable Storage

- Store the heating cable in a clean, dry place.
- Temperature range: -40°C to +60°C.
- Protect the heating cable from mechanical damage.

1.2 Pre-Installation Checks

Check materials received:

- Review the heating cable design and compare the list of materials to the catalogue numbers of heating cables and electrical components received to confirm that proper materials are on site. The heater type is printed on its jacket.
- Temperature exposure must not exceed that specified in Raychem product literature. Exceeding these limits will impair product performance. Check that expected exposure is within these limits.
- Ensure that the heating cable voltage rating is suitable for the service voltage available.
- Inspect heating cable and components for in-transit damage. An insulation resistance test on each reel is recommended.

Check piping to be traced:

- Complete the pipe pressure test.
- Walk the system and plan the routing of the heating cable on the pipe.
- Check pipework against specification drawing. If different consult design authority.
- Inspect piping for burrs, rough surfaces, sharp edges etc which could damage the heater. Smooth off or cover with layers of glass cloth tape or aluminium foil tape.

Heating Cable Installation Cont.

1.3 Heating Cable Handling

Heating cable handling tips:

- Paint and pipe coatings must be dry to the touch before heating cable installation.
- When pulling the heating cable, **AVOID**:
 - (1) Sharp edges
 - (2) Excessive pulling force
 - (3) Kinking and crushing
 - (4) Walking on it, or running over it with equipment

Heating cable pulling tips:

- Use a reel holder that pays out smoothly with little tension.
- Keep heating cable strung loosely but close to the pipe being traced to avoid interference with supports and equipment.
- Pay out minimum length of heater before fixing to pipe.
- Leave a 0.5m heating cable service loop at all power connection, splice, tee and end seal locations.
- Add additional heating cable to trace the fittings and supports or for spiralling as required by the design specifications, or consult Raychem product literature for design.
- Protect all heating cable ends from moisture, contamination and mechanical damage or other interference if left exposed for long periods of time before component installation.

1.4 Heating Cable Attachment Recommendations

- The heating cable may be installed straight, spiralled or in multiple runs as required by the design specification or Raychem product literature.
- **Do not** use metal attachments, vinyl electrical tape or duct tape as heating cable damage may result.
- Plastic cable ties must have a temperature rating that matches the system exposure temperature.
- Fix in place with glass cloth tape (see figure 1) at 300mm intervals and additionally where necessary.

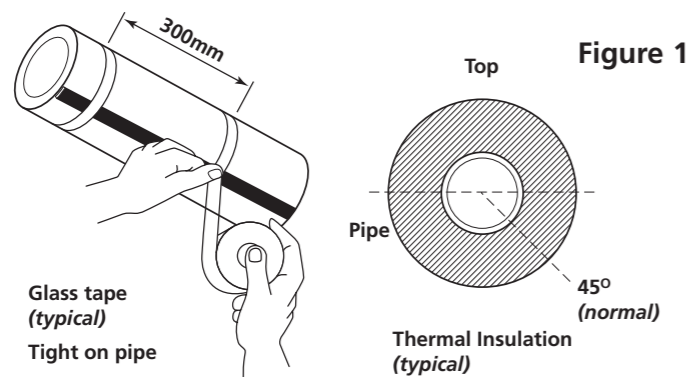

1.4.1 Straight Tracing

- Straight trace the pipe unless the design call for spiralling (see 1.4.2).
- On horizontal pipes fix on lower quadrant as shown in figure 1 and not on bottom of pipe.
- Thermally insulate and weatherproof to specification.

Raychem Attachment Tapes

- **GT-66 Fibreglass Tape**
General purpose tape
- **GS-54 Fibreglass Tape**
Recommended for use on stainless-steel surfaces and lower temperature installations as specified in Raychem product catalogue.
- **AT-180 Aluminium Tape**
Use only if the design requires it. AT-180 improves the heat transfer and increases the power output of the heating cable. Attach the heating cable to the pipe as shown in figure 2.

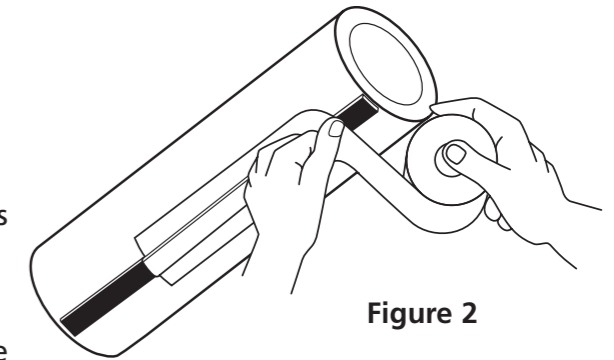

Figure 2

1.4.2 Spiral Tracing

- Alternative spiralling methods are shown in figures 2a and 2b.
- Only spiral heater on pipe when called for by design.

Figure 2a

- Heater cable length:
- pipe length x spiral ratio.
- Refer to design spec for spiral ratio.
- **Step 1 - Make starting loop as shown**
- **Step 2 - Grasp loop and wind around pipe**
- **Step 3 - Space evenly and attach pipe**
- Thermally insulate and weatherproof to specification.

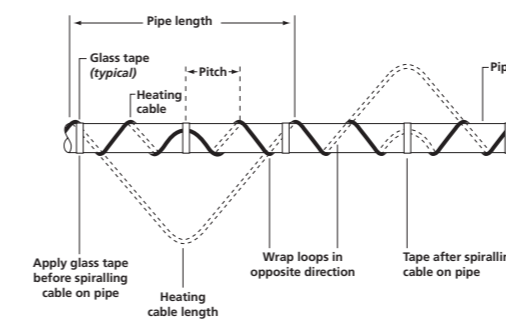
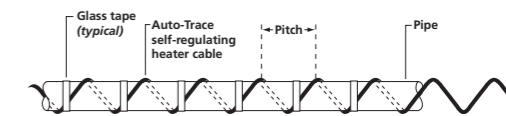

Figure 2b

- Refer to design specification for spiral pitch.
- Mark the pipe at the spiral pitch or use a simple length gauge.
- Fix the heater as installation progresses.
- Thermally insulate and weatherproof to specification.



Spiral Pitch Chart

NB (mm)	NPS (inches)	Spiral Ratio (Metres of Heater per Metre of Pipe)				
		1.1	1.2	1.3	1.4	1.5
25	1	250	170	140	110	100
32	1¼	310	210	170	140	130
40	1½	350	240	190	160	140
50	2	430	300	240	200	180
65	2½	520	360	290	240	210
80	3	630	430	350	290	260
100	4	800	560	440	370	330
150	6	1180	810	650	550	480
200	8	1520	1050	840	710	620

Example

- For pipe of 80mm NB (3" NPS) requiring 1.3m of cable per metre of pipe, pitch is 350mm.

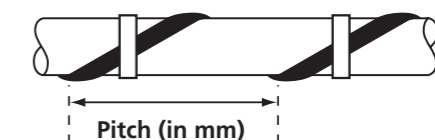

Heating Cable Installation Cont.

1.5 Cutting The Heating Cable

- Cut the heating cable to length after it is attached to the pipe. Before cutting it, confirm the tracing allowance as per Sections 1.3 and 1.6.
- Self-regulating cable can be cut to length without affecting the heat output per metre.

1.6 Typical Installation Details

- Typical installation details for fixing heater to pipe fittings are shown below and across.

General Notes:

- Trace pipe fittings as shown to allow easy maintenance.
- Consult the design specification or Raychem product literature for the tracing requirements for fittings and support.

1.6.1 Valve

- Refer to design specification for loop length.
- Fix with glass cloth tape.
- Thermally insulate and weatherproof to specification (including valve stem).

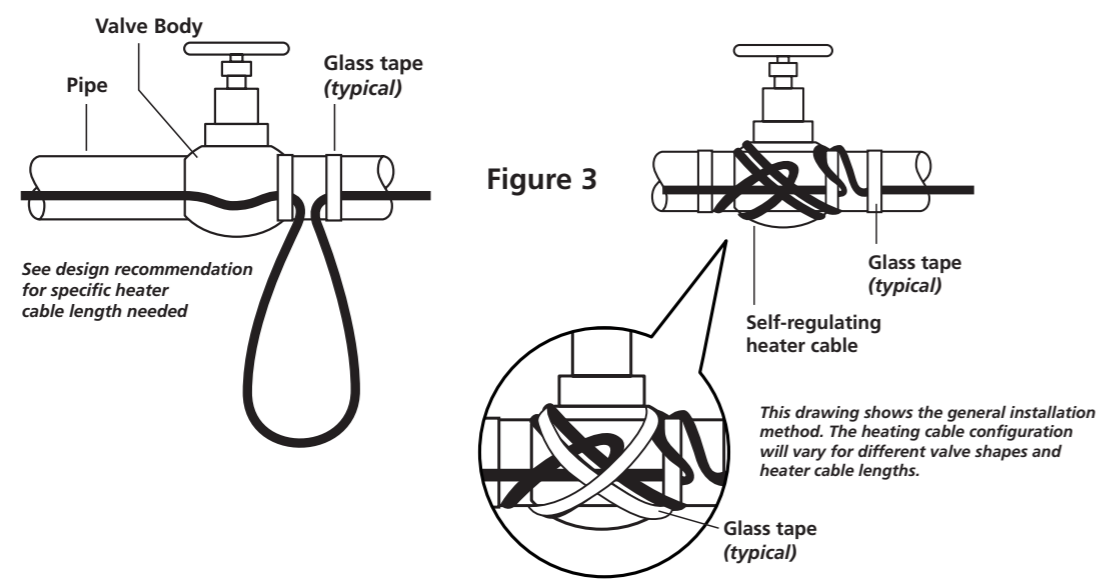

1.6.2 Elbow

- Fix heater to outside (long) radius of elbow.
- Fix with glass cloth tape.
- Thermally insulate and weatherproof to specification.

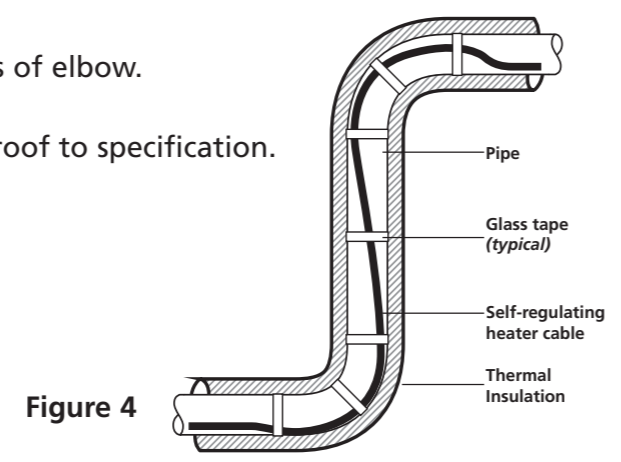

1.6.3 Flange

- Additional heating cable is 2 times diameter of pipe.
- Fix with glass cloth tape.
- Thermally insulate and weatherproof to specification.

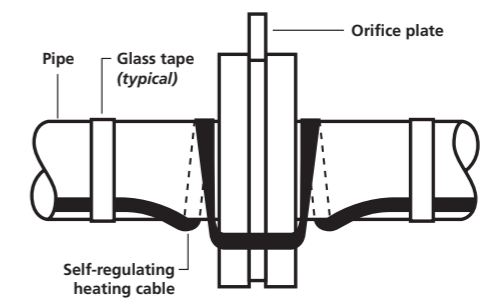

Figure 5

1.6.4 Pipe Bar Hanger

- Do not clamp heating cable with support. Heater must be over the support.
- No additional heating cable is required for bar or rod pipe hangers.
- Fix with glass cloth tape.
- Thermally insulate and weatherproof to specification.

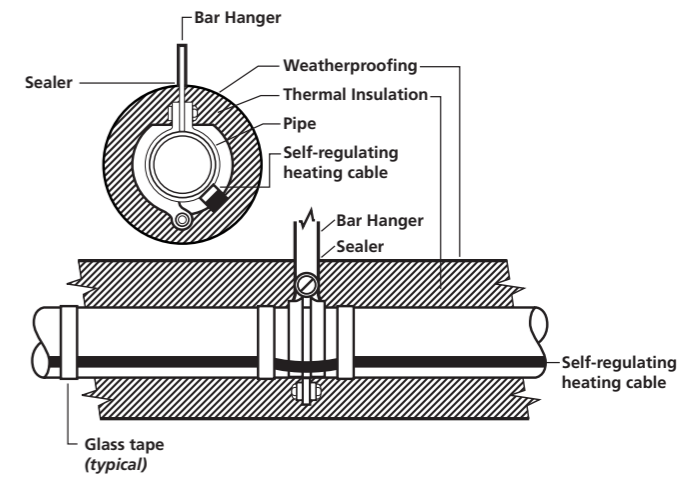

Figure 6

1.6.5 Pipe Support Shoe

- Fix with glass cloth tape.
- Thermally insulate and weatherproof to specification.

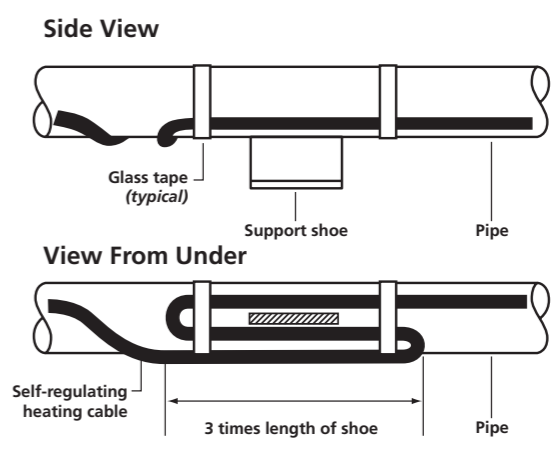

Figure 7

Pipe Heat Loss

- Pipe heat loss (Q_p) is shown in watts per minute (W/m).
- Heat loss calculation is based on metal pipes insulated with glass fibre and located outdoors in a 8.9 m/s wind.
- A 10% safety factor has been included.
- For indoor applications multiply heat loss by 0.9.

Insulation Thickness (mm)	ΔT (°C)	Pipe Size							
		NB (mm)	8 NPS (inches)	15	20	25	32	40	50
		14	21	27	34	42	48	60	
10	20	6.2	7.2	8.5	10.1	12.1	13.6	16.4	
	30	9.4	11.0	12.9	15.4	18.5	20.7	24.9	
	40	12.7	14.9	17.5	20.8	25.0	27.9	33.7	
20	20	4.0	4.6	5.3	6.2	7.3	8.0	9.5	
	30	6.2	7.0	8.1	9.4	11.1	12.2	14.5	
	40	8.3	9.5	10.9	12.7	15.0	16.5	19.6	
	60	12.8	14.7	16.9	19.6	23.1	25.5	30.2	
25	20	3.6	4.1	4.6	5.3	6.2	6.9	8.1	
	30	5.4	6.2	7.1	8.1	9.5	10.4	12.3	
	40	7.4	8.4	9.5	11.0	12.9	14.1	16.6	
	60	11.4	12.9	14.7	17.0	19.8	21.8	25.6	
	80	15.6	17.7	20.2	23.3	27.2	29.9	35.1	
	100	20.1	22.8	26.1	30.1	35.1	38.6	45.4	
30	20	3.3	3.7	4.2	4.8	5.5	6.1	7.1	
	30	5.0	5.6	6.3	7.3	8.4	9.2	10.8	
	40	6.7	7.6	8.6	9.8	11.4	12.5	14.6	
	60	10.3	11.7	13.2	15.1	17.6	19.2	22.5	
	80	14.2	16.0	18.2	20.8	24.1	26.4	30.9	
	100	18.3	20.7	23.4	26.8	31.1	34.1	39.8	
	120	22.7	25.6	29.0	33.2	38.6	42.2	49.3	
	140	27.2	30.8	34.9	40.0	46.4	50.8	59.4	
	160	32.1	36.2	41.1	47.1	54.6	59.8	69.9	
	180	37.1	42.0	47.6	54.5	63.2	69.2	80.9	
40	20	2.8	3.2	3.6	4.0	4.6	5.0	5.8	
	30	4.3	4.8	5.4	6.1	7.0	7.7	8.9	
	40	5.8	6.5	7.3	8.3	9.5	10.4	12.0	
	60	9.0	10.1	11.3	12.8	14.7	16.0	18.5	
	80	12.3	13.8	15.5	17.6	20.2	21.9	25.4	
	100	15.9	17.8	20.0	22.7	26.0	28.3	32.8	
	120	19.7	22.1	24.8	28.1	32.2	35.1	40.6	
	140	23.7	26.5	29.8	33.8	38.8	42.2	48.8	
	160	27.9	31.2	35.1	39.8	45.6	49.7	57.4	
	180	32.3	36.2	40.6	46.0	52.9	57.5	66.5	
50	20	2.6	2.8	3.2	3.6	4.1	4.4	5.0	
	30	3.9	4.3	4.8	5.4	6.2	6.7	7.7	
	40	5.3	5.9	6.5	7.3	8.4	9.1	10.4	
	60	8.1	9.0	10.1	11.3	12.9	14.0	16.0	
	80	11.2	12.4	13.8	15.5	17.7	19.1	22.0	
	100	14.4	16.0	17.8	20.1	22.8	24.7	28.4	
	120	17.8	19.8	22.1	24.8	28.3	30.6	35.1	
	140	21.5	23.8	26.6	29.9	34.0	36.8	42.3	
	160	25.3	28.1	31.3	35.2	40.1	43.4	49.8	
	180	29.2	32.5	36.2	40.7	46.4	50.2	57.6	
80	20	2.1	2.3	2.6	2.8	3.2	3.4	3.8	
	30	3.2	3.5	3.9	4.3	4.8	5.2	5.8	
	40	4.4	4.8	5.2	5.8	6.5	7.0	7.9	
	60	6.7	7.4	8.1	9.0	10.0	10.8	12.1	
	80	9.2	10.1	11.1	12.3	13.8	14.8	16.6	
	100	11.9	13.0	14.3	15.9	17.8	19.1	21.5	
	120	14.7	16.1	17.8	19.7	22.0	23.6	26.6	
	140	17.7	19.4	21.4	23.6	26.5	28.4	32.0	
	160	20.9	22.9	25.1	27.8	31.2	33.4	37.7	
	180	24.1	26.5	29.1	32.2	36.1	38.7	43.7	

65	80	100	150	200	250	300	350	400	450	500	600
2 1/2	3	4	6	8	10	12	14	16	18	20	24
76	89	114	168	219	273	324	356	406	457	508	610
19.3	23.0	28.8	41.16	52.6	64.7	76.1	83.3	94.6	105.9	117.2	139.7
29.4	35.0	43.8	2.5	80.0	98.5	115.8	126.7	143.9	161.1	178.3	212.6
39.7	47.3	59.2	84.5	108.2	132.2	156.6	171.3	194.6	217.9	241.1	287.4
11.1	13.0	16.0	22.5	28.5	34.9	40.9	44.7	50.7	56.7	62.6	74.6
16.8	19.8	24.4	34.2	43.4	53.2	62.3	68.0	77.1	86.2	95.3	113.4
22.8	26.7	33.0	46.3	58.7	71.9	84.2	92.0	104.3	116.6	128.9	153.4
35.1	41.2	50.9	71.4	90.5	110.8	129.9	141.8	160.8	179.7	198.7	236.5
9.3	10.9	13.4	18.6	23.5	28.7	33.5	36.5	41.4	46.2	51.1	60.7
14.2	16.6	20.3	28.3	35.7	43.6	51.0	55.6	63.0	70.3	77.7	92.4
19.2	22.4	27.5	38.2	48.3	59.0	69.0	75.2	85.2	95.1	105.1	124.9
29.6	34.5	42.4	59.0	74.5	90.9	106.3	115.9	131.3	146.7	162.0	192.6
40.6	47.4	58.2	81.0	102.3	124.8	146.0	159.2	180.3	201.4	222.4	264.5
52.5	61.2	75.2	104.5	132.0	161.1	188.5	205.5	232.8	260.0	287.2	341.5
8.1	9.5	11.6	15.9	20.1	24.4	28.5	31.0	35.1	39.2	43.2	51.3
12.4	14.4	17.6	24.3	30.5	37.1	43.3	47.2	53.4	59.6	65.8	78.1
16.8	19.5	23.8	32.8	41.3	50.2	58.6	63.8	72.2	80.6	88.9	105.6
25.9	30.0	36.6	50.6	63.6	77.4	90.4	98.4	111.4	124.3	137.1	162.9
35.5	41.2	50.3	69.4	87.3	106.3	124.0	135.1	152.9	170.6	188.3	223.6
45.8	53.2	65.0	89.7	112.8	137.2	160.2	174.5	197.4	220.3	243.1	288.7
56.7	65.9	80.4	111.0	139.6	169.9	198.3	216.1	244.4	272.8	301.0	357.5
68.3	79.3	96.8	133.5	168.0	204.4	238.6	259.9	294.0	328.1	362.1	430.1
80.4	93.3	113.9	157.2	197.7	240.6	280.8	306.0	346.1	386.2	426.3	506.2
93.0	108.1	131.9	182.0	228.9	278.6	325.2	354.2	400.7	447.1	493.5	586.2
6.6	7.6	9.2	12.6	15.7	19.0	22.1	24.0	27.1	30.2	33.3	39.4
10.1	11.6	14.1	19.1	23.9	28.9	33.6	36.6	41.3	45.9	50.6	60.0
13.7	15.7	19.0	25.9	32.3	39.1	45.5	49.4	55.8	62.1	68.5	81.1
21.1	24.3	29.3	39.9	49.8	60.3	70.1	76.2	86.0	95.8	105.6	125.1
28.9	33.3	40.2	54.8	68.4	82.7	96.2	104.6	118.1	131.5	144.9	171.7
37.3	43.0	52.0	70.8	88.3	106.8	124.2	135.1	152.4	169.8	187.1	221.7
46.2	53.3	64.4	87.6	109.3	132.3	153.9	167.3	188.8	210.3	231.7	274.5
55.6	64.1	77.4	105.4	131.5	159.1	185.1	201.2	227.1	252.9	278.7	330.2
65.5	75.4	91.1	124.1	154.8	187.3	217.9	236.9	267.3	297.7	328.1	388.7
75.8	87.3	105.5	143.7	179.3	216.9	252.2	274.3	309.5	344.7	379.9	450.1
5.7	6.5	7.8	10.5	13.1	15.7	18.2	19.8	22.3	24.7	27.2	32.2
8.7	9.9	11.9	16.0	19.9	23.9	27.7	30.1	33.9	37.6	41.4	48.9
11.8	13.4	16.1	21.7	26.9	32.3	37.5	40.7	45.8	50.9	56.0	66.2
18.1	20.7	24.8	33.4	41.4	49.9	57.8	62.7	70.6	78.5	86.3	102.1
24.9	28.5	34.1	45.9	56.8	68.4	79.3	86.1	96.9	107.7	118.5	140.1
32.1	36.7	44.0	59.2	73.4	88.3	102.4	111.1	125.1	139.1	153.0	180.9
39.8	45.5	54.5	73.3	90.9	109.4	126.8	137.6	154.9	172.2	189.5	224.0
47.9	54.7	65.6	88.2	109.3	131.6	152.5	165.5	186.4	207.2	227.9	269.4
56.3	64.4	77.2	103.9	128.7	154.9	179.5	194.9	219.4	243.9	268.3	317.2
65.2	74.6	89.4	120.3	149.0	179.4	207.9	225.6	254.0	282.4	310.7	367.2
4.3	4.8	5.7	7.4	9.0	10.7	12.3	13.3	14.9	16.4	18.0	21.1
6.5	7.3	8.6	11.3	13.7	16.3	18.7	20.2	22.6	25.0	27.4	32.1
8.8	9.9	11.6	15.2	18.5	22.0	25.3	27.3	30.6	33.8	37.0	43.5
13.5	15.3	17.9	23.5	28.6	34.0	39.0	42.1	47.1	52.1	57.1	67.0
18.6	20.9	24.6	32.2	39.2	46.6	53.5	57.8	64.7	71.5	78.3	92.0
24.0	27.0	31.8	41.6	50.6	60.2	69.1	74.6	83.5	92.3	101.2	118.8
29.7	33.5	39.3	51.5	62.7	74.5	85.5	92.4	103.4	114.3	125.3	147.1
35.7	40.3	47.3	61.9	75.4	89.6	102.9	111.2	124.4	137.5	150.7	176.9
42.1	47.4	55.7	72.9	88.8	105.5	121.1	130.9	146.4	161.9	177.4	208.3
48.7	54.9	64.5	84.4	102.8	122.2	140.3	151.5	169.5	187.5	205.4	241.2

Insulation Factors	Pipe Insulation	Insulation	Thermal Conductivity At 10°C Mean Temp (W/mK)
	Glass Fibre	1.0	0.036
	Mineral Wool (Rockwool)	1.06	0.038
	Mineral Fibre Blanket	1.20	0.043
	Foamed Elastomer	1.17	0.042
	Rigid Cellular Polyurethane	0.67	0.024
	Calcium Silicate Block	1.50	0.054
	Cellular Glass	1.61	0.058
	Expanded Perlite	1.50	0.054

1 W/mK = 0.86kcal/mhK

Valve Heat Loss Factor	Valve Type	Heat Loss (Metre Equivalent)
	Gate	1.3
	Butterfly	0.7
	Ball	0.8
	Globe	1.2

Heat Tracing Plastic Pipes With Raychem Self-Regulating Heaters

General Information

Raychem self-regulating heaters are ideal for heat tracing plastic pipes. The self-regulating feature of Raychem cable enables the heater to vary its response to sensed temperatures at each point along the circuit. This means the heater's power output will not overheat the pipe, even where overlapped.

Raychem BTV-CR and BTV-CT can be used safely and without over-heating on any of the common plastic pipe materials. These products have a tinned copper braid which provides the earth path in the case of an earth fault. Consult Cable Services regarding other applications and the use of other Auto-Trace products on plastic pipes.

Table 1

The following table lists generally accepted maximum allowable temperature for various plastic pipe materials:

Polyethylene	50°C
PVC	60°C
ABS	70°C
Polypropylene	70°C
CPVC	80°C
FRP	95°C

Caution:

These are typical values. The temperature ratings of plastic pipes depend upon operating pressure, so service temperature ratings may be lower (consult the pipe manufacturer's literature).

Design

The thermal conductivity of plastics is much lower than that of carbon steel (approximately 150 times less). This lower thermal conductivity does not appreciably affect the heat loss from the system, but does affect the thermal environment around the Auto-Trace heater. The increased resistance to heat transfer from the heater necessitates compensation of the heater's power output.

Factors which affect the thermal output of Raychem heaters are the heater geometry, plastic pipe wall thickness, and the use of heat transfer aids, e.g. aluminium tape.

Extensive testing of Raychem products has determined the effect for these factors on heater power output. Power output adjustment factors for typical applications are shown in Table 2. These adjustment factors are applied to the power output for insulated steel pipes to give output for insulated plastic pipes.

ATE-180 aluminium tape may be used to increase the output of Raychem's heaters on plastic pipes. The design may consider installation with glass cloth tape (not ATE-180) with ATE-180 over the Raychem heater, or with ATE-180 both under and over the heater. Power output adjustment factors for these alternatives are included in Table 2.

Table 2

Power output adjustment factors (pipe wall thickness 6mm or less).

	Without ATE-180 aluminium tape	With ATE-180 aluminium tape* over heater	With ATE-180 aluminium tape* under & over heater
3BTV2	0.60	0.75	0.85
5BTV2	0.50	0.75	0.80
8BTV2	0.45	0.65	0.75
10BTV2	0.45	0.70	0.75

*Applied longitudinally along heater length

Chart Ratings (Industrial Heaters) Raychem Regulating Heaters

Catalogue Number	For Temperature Maintenance Up To (°C)	Nominal Supply Voltage Vac	Maximum Circuit Length	Maximum Exposure Temperatures	
				Continuous	Intermittent
3 BTV1	65	110	100m	65°C	85°C
5 BTV1		110	80m	65°C	85°C
8 BTV1		110	65m	65°C	85°C
10 BTV1		110	55m	65°C	85°C
10 QTV1	110	110	50m	110°C	135°C
15 QTV1		110	60m	110°C	135°C
20 QTV1		110	55m	110°C	135°C
5 KTV-1		110	115m	150°C	215°C **
8 KTV-1	150	110	90m	150°C	215°C **
15 KTV-1		110	65m	150°C	215°C **
20 KTV-1		110	55m	150°C	215°C **
3 BTV2		65	230	200m	65°C
5 BTV2	230		165m	65°C	85°C
8 BTV2	230		130m	65°C	85°C
10 BTV2	230		105m	65°C	85°C
10 QTV2	110	230	115m	110°C	135°C
15 QTV2		230	100m	110°C	135°C
20 QTV2		230	110m	110°C	135°C
4 XTV2		120	230	250m	120°C
8 XTV2	230		180m	120°C	215°C **
12 XTV2	230		145m	120°C	215°C **
15 XTV2	230		130m	120°C	215°C **
20 XTV2	150	230	110m	120°C	215°C **
5 KTV-2		230	225m	150°C	215°C **
8 KTV-2		230	180m	150°C	215°C **
15 KTV-2		230	130m	150°C	215°C **
20 KTV-2	230	110m	150°C	215°C **	

**20 bars saturated steam (maximum cumulative exposure 1000 hours)

Approval authorities worldwide have permitted the installation of the braided versions of Raychem products in hazardous areas without thermostatic controls.

For specific approvals information, see the product data sheets or contact Cable Services.

Non-Self Regulating Heaters

Catalogue Number	For Temperature Maintenance Up To (°C)	Nominal Supply Voltage Vac	Maximum Circuit Length	Power Off
5 VPL	230	230	225m	250°C
10 VPL		230	160m	250°C
15 VPL		230	130m	250°C
20 VPL		230	110m	250°C
IHT / 2 / 10-CT	125	230	120m	200°C
IHT / 2 / 20-CT		230	90m	200°C
IHT / 2 / 30-CT		230	75m	200°C
FHT / 2 / 10-CT	200	230	200m	260°C
FHT / 2 / 20-CT		230	150m	260°C
FHT / 2 / 30-CT		230	120m	260°C
FG 260 - 10	200	230 or 110	160m or 80m	260°C
FG 260 - 20		230 or 110	100m or 50m	260°C
FG 260 - 30		230 or 110	90m or 40m	260°C
FG 260 - 40		230	60m	260°C

Ratings for other products (PYRO etc.) available on request.

Raychem WINTERGARD

Application

Frost protection for pipework at max. 65°C operating temperature.

FS-A-2X	10 W/m at 5°C
FS-B-2X	26 W/m at 5°C

Frost protection for pipework at max. 95°C operating temperature and temperature maintenance for metal waste pipes with fatty waste water.

FS-C-2X	31 W/m at 5°C
	22 W/m at 40°C

Heater Selection

Frost protection up to -20°C.

Cable Type	Pipe Diameter	Insulation Thickness											
		15 1/2	22 3/4	28 1	35 1 1/4	42 1 1/2	54 2	67 2 1/2	76 3	108 4	125 5	150 6	200 (mm) 8 (inches)
FS-A-2X	10mm	FS-A-2X	FS-B-2X	FS-B-2X	FS-B-2X	FS-B-2X	FS-B-2X	FS-B-2X	FS-B-2X				
FS-A-2X	15mm	FS-A-2X	FS-A-2X	FS-A-2X	FS-B-2X	FS-B-2X	FS-B-2X	FS-B-2X	FS-B-2X	FS-B-2X	FS-B-2X		
FS-A-2X	20mm	FS-A-2X	FS-A-2X	FS-A-2X	FS-A-2X	FS-A-2X	FS-B-2X	FS-B-2X	FS-B-2X	FS-B-2X	FS-B-2X	FS-B-2X	
FS-A-2X	25mm	FS-A-2X	FS-A-2X	FS-A-2X	FS-A-2X	FS-A-2X	FS-A-2X	FS-B-2X	FS-B-2X	FS-B-2X	FS-B-2X	FS-B-2X	
FS-A-2X	30mm	FS-A-2X	FS-A-2X	FS-A-2X	FS-A-2X	FS-A-2X	FS-A-2X	FS-A-2X	FS-B-2X	FS-B-2X	FS-B-2X	FS-B-2X	FS-B-2X
FS-A-2X	40mm	FS-A-2X	FS-A-2X	FS-A-2X	FS-A-2X	FS-A-2X	FS-A-2X	FS-A-2X	FS-A-2X	FS-B-2X	FS-B-2X	FS-B-2X	FS-B-2X
FS-A-2X	50mm	FS-A-2X	FS-A-2X	FS-A-2X	FS-A-2X	FS-A-2X	FS-A-2X	FS-A-2X	FS-A-2X	FS-A-2X	FS-B-2X	FS-B-2X	FS-B-2X

Frost protection cables FS-A-2X and FS-B-2X are suitable for any pipe material (copper, threaded pipes, stainless steel, plastic pipes and composite metal pipes without restriction).

For plastic pipes, please use aluminium adhesive tape ATE-180. The frost protection cable should be covered along its entire length. Heat insulation $\lambda = 0.035 \text{ W/(m.K)}$ or better.

Raychem HWAT (Hot Water Temperature Maintenance)

Design Guide

Application

Optimum water temperature maintenance for single family houses, flats, offices, hotels, hospitals, convalescent homes, sports centres, etc.

Heating Cable Type	HWAT-L	HWAT-M	HWAT-R
Maintenance Temperature	Typically 45°C	Typically 55°C	Variable 50-70°C
Max. Exposure Temperature	65°C	65°C	80°C
Outer Jacket Colour	Yellow	Orange	Red
Control unit HWAT-ECO	-	Compatible	Essential
Timer QWT-04	Recommended	-	-
Legionella Prevention			Possibility of thermal legionella prevention up to the draw off points

Insulation Thickness

Pipe Size (mm)	15	22	28	35	42	54
Insulation Thickness (mm)	20	20	25	30	40	50

Ambient Temperature: 18°C
Thermal conductivity $\lambda = 0.035 \text{ W/(m.K)}$
For other thermal conductivity insulation materials, contact Cable Services.

Electrical Protection

- The total length of heating cable determines the number and size of the circuit breakers.
- Residual current device (rcd): 30 mA required.
- The power connection must be carried out by an approved electrical installer.

Circuit-breaker to BSEN 60898 (type C): the maximum length of the heating circuit is based on a minimum start-up temperature of +12°C, 230 VAC.

	HWAT-L	HWAT-M	HWAT-R
10 A	80m	50m	50m
13 A	110m	65m	65m
16 A	140m	80m	80m
20 A	180m	100m	100m

Troubleshooting Guide

Symptoms

A Overcurrent protection trips or blows	
Probable Cause	Corrective Action
1 Electrical fault at: a damaged heater b faulty splices or tees c end seal d connection	1 Investigate and remedy (see note 1):
2 Circuit oversized.	2 Resize or design within Electrical Protection Bulletin Guidelines. (If larger protection required, ensure supply cables are compatible).
3 Start-up below design temperature.	3 a Redesign for lower start-up temperatures. b Preheat pipes from alternative heat source to within exposure temperature given in Product Data Sheet. c Energise part of circuit followed by reminder (e.g. in sequence).
4 Defective protection.	4 Replace.

Symptoms

B RCCB trips	
Probable Cause	Corrective Action
1 Electrical fault at: a damaged heater b faulty splices or tees c end seal d connection	1 Investigate and remedy (see note 1):
2 Excessive moisture in: a junction boxes b splices or tees c end seal	2 Dry out and reseal or remake immediately. Perform insulation test (10 M Ω minimum).
3 High capacitance leakage due to excessive power cable and Auto Trace lengths.	3 Redesign within Electrical Protection Bulletin Guidelines.
4 Main borne disturbances.	3 Redesign within Guidelines available from Raychem.
5 Defective RCCB.	5 Replace.

Symptoms

C No power output	
Probable Cause	Corrective Action
1 Loss of supply voltage due to: a Overcurrent or residual current protection operating. b Loose terminals in junction boxes. c Loss of supply cable continuity (e.g. open circuited from damage).	1 Restore supply voltage: a Following A and B across page. b Re-tighten terminals NB. If excessive heating has occurred due to high resistance, replace terminals or crimps. c Locate damage and repair.
2 Control thermostat is connected in the normally open position.	2 Re-connect to normally closed position.
3 High resistance connection at: a Junction box terminals. b Splices or tees	3 Locate and remedy by: a Re-tighten. b Repair. NB. If excessive heating has occurred due to high resistance, replace terminals or crimps.

Symptoms

D Low pipe temperature	
Probable Cause	Corrective Action
1 Wet thermal insulation.	1 Remove and replace with dry insulation of correct specification and ensure complete weatherproofing.
2 Design error.	2 a Check with competent authority for design conditions. b Modify to meet Raychem recommendations.
3 Incorrect setting or operation of controls e.g. thermostat.	3 Repair or reset to correct level of operation.
4 Heater has been exposed to excessive temperature beyond rating.	4 Replace.

NOTE:

Locate faults by the following steps:

1. Visually inspect the power connections, splices and end seals for correct installation.
2. Look for signs of damage at:
 - (a) Valves, pumps, flanges and supports.
 - (b) Areas where repairs or maintenance work has been carried out.
3. Look for crushed or damaged insulation and cladding along the pipe.
4. If after 1, 2 and 3 above the fault has not been located, then either:
 - (a) Consult Cable Services for further assistance.
 - (b) Where local practices and conditions allow (e.g. non-hazardous areas) isolate one section of heater from another by cutting or half and testing (e.g. Insulation Resistance) both halves until general area of damage is found. Remove insulation and expose fault.

Raychem DigiTrace Thermostats

Surface Sensing - Ordinary

Description	Temp.Setting Controller	Exposure Temp. Sensor	Voltage
Electronic			
AT-TS-13	-5°C +15°C	-20°C +160°C	230V
AT-TS-14	0°C +120°C	-20°C +160°C	230V
RAYSTAT-CONTROL-10	0°C +150°C	-40°C +150°C	230V
Panelmount			
TCONTROL-CONT-02	Configurable between -1999 and +9999	Depending on type of sensor used*	110 / 240V
TCON-CSD/07/0-100C	Ranges 0°C +100°C	Depending on type of sensor used*	230V
TCON-CSD/07/0-200C	Ranges 0°C +200°C	Depending on type of sensor used*	230V
Mechanical			
T-M-10-S/0+50C	0°C +50°C	-40°C +60°C	Upto 230V
T-M-10-S/0+200C	0°C +200°C	-20°C +230°C	Upto 230V
T-M-10-S/0+50+300C	+50°C +300°C	-20°C +345°C	Upto 230V
Mechanical Dual Sensing			
T-M-20-S/0+50C	0°C +50°C	-40°C +60°C	Upto 230V
T-M-20-S/0+200C	0°C +200°C	-20°C +230°C	Upto 230V
T-M-20-S/0+50+300C	+50°C +300°C	-20°C +345°C	Upto 230V

Surface Sensing - Hazardous

Description	Temp.Setting Controller	Exposure Temp. Sensor	Voltage
Electronic			
RAYSTAT-EX-03	0°C +499°C	-50°C +585°C	110 / 240V
Mechanical			
RAYSTAT-EX-02	-4°C +163°C	-50°C +215°C	240V
Mechanical Dual Sensing			
T-M-20-S/+5+215C/EX	+5°C +215°C	-30°C +250°C	Upto 400V
T-M-20-S/+70+350C/EX	+70°C +350°C	-30°C +380°C	Upto 400V

(* These systems can depending on the application be used with the following sensors: MONI-PT100-EXE and MONI-PT100-EXE-SENSOR (hazardous area), MONI-PT100-NH (ordinary area), MONI-PT100-4/20MA (intrinsic safe, TCONTROL-CONT-02 only).

Raychem DigiTrace Thermostats

Ambient Sensing - Ordinary

Description	Temp.Setting Controller	Exposure Temp. Sensor	Voltage
Electronic			
AT-TS-13	-5°C +15°C		230V
RAYSTAT-ECO-10	0°C +30°C		230V
Mechanical			
T-M-10-S/0+50C	0°C +50°C		Upto 230V

Ambient Sensing - Hazardous

Description	Temp.Setting Controller	Exposure Temp. Sensor	Voltage
Electronic			
RAYSTAT-EX-04	0°C +49°C		110 / 240V

Rule of Thumb!

Useful Design Information

Calculating Heat Losses On Uninsulated Pipes

Indoors
9.4 watts X surface area in metres squared X °C of Delta T.

Outdoors
30 watts X surface area in metres squared X °C of Delta T. (assuming 20mph wind)

Add a least 10% margin for error (Delta T = required maintained temperature minus the minimum ambient temperature.)

NB: Heater output halved in free air.

Calculating Surface Areas

Cylindrical = $\pi \times D \times H$
Circle = πR^2
Sphere = $4 \pi R^2$
Hemisphere = $2 \pi R^2$
Cone = $\pi \times (R + r) \times \sqrt{(R - r)^2 + H^2}$



CABLE SERVICES



RS 21752
Cable Services
RS 26602
Smith Electrical

**Cable Services Ltd
(NW / UK / Export)**

Rhosddu Industrial Estate,
Rhosrobin, Wrexham LL11 4YZ.

Tel: 01978 340450

Fax: 01978 311315

Email: uk@cableservices.co.uk

(Central) Ltd

Unit 7-11 Douglas Park, Opal Way,
Stone Business Park, Stone, Staffs ST15 0YJ

Tel: 01785 825970 • Fax: 01785 825977

Email: central@cableservices.co.uk

(Liverpool) Ltd

43 St. Johns Road, Liverpool L20 8AZ.

Tel: 0151 9339022 • Fax: 0151 9339765

Email: lpool@cableservices.co.uk

(Smith Electrical) Ltd

Hawbank House, 21/23 Hawbank Road,
College Milton, East Kilbride G74 5EG

Tel: 0141 621 2060 • Fax: 01355 238502

Email: scotland@cableservices.co.uk